

Enprag s.r.o.  
K holyni 42  
150 00 Praha 5 - Slivenec  
IČ 62743741  
DIČ CZ62743741

## Test report 26042830 - Measurement of product properties for electrostatic protection

Type: perfopanel ESD

Measurement performed by: Lukáš Kempný  
Report compiled: Lukáš Kempný  
Day: 28.04.2026

## Instruments used

Electrofieldmeter -- TE350 -- SN09100721 -- calibration date 6/2025

## Measurement description

The measurement was conducted to demonstrate product compliance with the standard ČSN EN 61340-5-1 ed.3:2017 Electrostatics - Part 5-1: Protection of electronic components from electrostatic phenomena - General requirements.

The measurement took place on ENPRAG company premises (Temperature: 18°C, Relative Humidity: 34%). No special cleaning of the product was performed before measurement.

## Requirements for the product specified in ČSN EN 61340-5-1 ed.3:2017

Table 3 - Requirements for EPA areas

Object for ESD suppression	Product qualification <sup>a</sup>		Verification of compliance <sup>b</sup>	
	Testing method	Limit <sup>c</sup>	According to testing method	Limit <sup>c</sup>
Working surfaces, storage shelves and carts <sup>g</sup>	IEC 61340-2-3	$R_{pp} < 1 \times 10^9 \Omega$	IEC 61340-2-3	$R_p < 1 \times 10^9 \Omega$
		$R_{p-p} < 1 \times 10^9 \Omega'$		
Grounding point for wristbands				$R_p < 5 \times 10^6 \Omega$
Floors	IEC 61340-4-1 <sup>d,e</sup>	$R_{pp} < 1 \times 10^9 \Omega$	IEC 61340-4-1	$R_p < 1 \times 10^9 \Omega$
Ionization	IEC 61340-4-7	Decay (1,000 V to 100 V and -1,000 V to -100 V) < 20 s	IEC 61340-4-7	Decay (1,000 V to 100 V and -1,000 V to -100 V) < 20 s or according to user
		Offset voltage < ±35 V		Offset voltage < ±35 V
Chairs	IEC 61340-2-3 (measuring resistance to ground point)	$R_{pp} < 1 \times 10^9 \Omega$	IEC 61340-2-3 (measuring resistance to earth)	$R_p < 1 \times 10^9 \Omega$
Garments for suppressing electrostatic charge	IEC 61340-4-9 or method according to user	$R_{p-p} < 1 \times 10^{11} \Omega$ or limit according to user	IEC 61340-4-9 or method according to user	$R_{p-p} < 1 \times 10^{11} \Omega$ or limit according to user

Groundable garments for suppressing electrostatic charge	IEC 61340-4-9	$R_{pp} < 1 \times 10^9 \Omega$	IEC 61340-4-9	$R_{pp} < 1 \times 10^9 \Omega$
--	---------------	---------------------------------	---------------	---------------------------------

<sup>a</sup> For product qualification, the environmental conditions for testing should be  $(12 \pm 3)\%$  relative humidity and  $(23 \pm 2)^\circ\text{C}$ . If the target IEC standard does not specify a minimum conditioning time before qualification testing, then this period should be 48 hours.

<sup>b</sup> Testing methods in the column for verification of compliance refer only to the basic testing procedure and complete implementation of the testing method is not expected.

<sup>c</sup>  $R_p$  in the table means resistance to earth and  $R_{pp}$  means resistance to ground point.

<sup>d</sup> Maximum permitted test voltage for measuring ESD floors that should be used for an ESD program complying with this standard is 100 V.

<sup>e</sup> If the floor is used for grounding personnel who handle ESDS, then the system requirements are in table 2.

<sup>f</sup> In cases where damage according to the charged device model (CDM) is considered, a lower limit for resistance between points of  $1 \times 10^4 \Omega$  is recommended.

1) Grounding point for wrist straps  $R_g < 5 \times 10^6 \Omega$ .

2) Work surfaces  $R_{gp} < 1 \times 10^9 \Omega$ , measured according to ČSN EN 61340-2-3 ed.2:2017 point 8.4.3.2

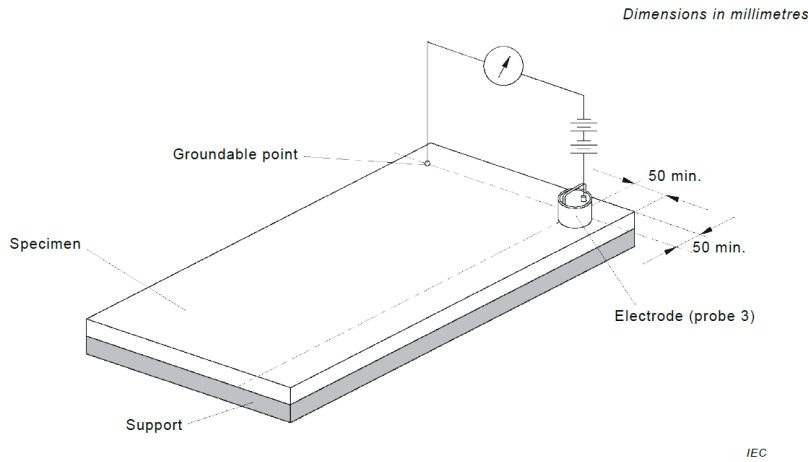

**Figure 5 – Principle of resistance to groundable point measurements**

#### 8.4.3.2 Measurements on installed materials

Put the electrode assembly (probe 3) onto the surface of the specimen in a position at least 50 mm away from the specimen edges or groundable point (see Figure 5). Connect the electrode assembly to one lead of the instrumentation and the groundable point to the other lead.

3) Work surfaces  $R_{p-p} < 1 \times 10^9 \Omega$ , measured according to ČSN EN 61340-2-3 ed.2:2017 point 8.4.4

IEC 61340-2-3:2016 © IEC 2016

– 17 –

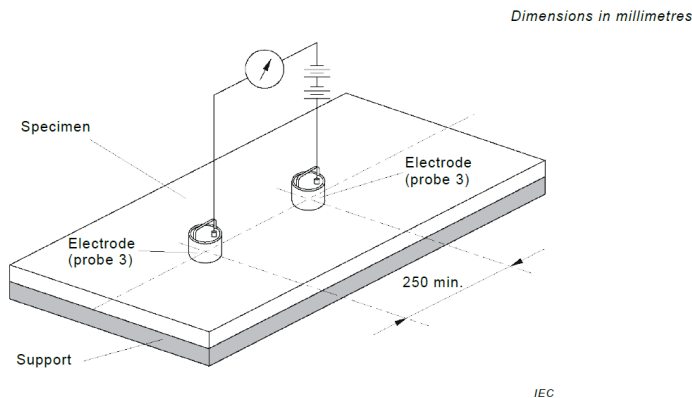

**Figure 6 – Principle of point-to-point measurements**

#### 8.4.4 Point-to-point resistance measurements

Connect two electrode assemblies (probes 3) described in 8.2.4 to the instrumentation. The specimen shall be placed onto the test support with the surface to be tested facing up. The probes shall be then placed onto the surface of the specimen in a specified or, if appropriate, otherwise chosen position at least 250 mm in distance from their longitudinal axes, and at least 50 mm away from the edges of the specimen (see Figure 6).

Energize the instrumentation at  $(10,0 \pm 0,5)$  V and record the reading after  $(15 \pm 1)$  s if the indicated resistance is less than  $1,0 \times 10^6 \Omega$ . Then proceed to the next position or specimen. If the indicated resistance is equal or higher than  $1,0 \times 10^6 \Omega$ , de-energize the instrumentation and repeat the procedure using  $(100 \pm 5)$  V.

## Results

	Measured value	Required value	Výsledek
Work surface Rgp main board	$4 \times 10^6 \Omega$	$< 1 \times 10^9 \Omega$	OK
Work surface Rgp main board	$5 \times 10^6 \Omega$	$< 1 \times 10^9 \Omega$	OK
Work surface Rgp main board	$8 \times 10^6 \Omega$	$< 1 \times 10^9 \Omega$	OK
Work surface Rgp main board	$10 \times 10^6 \Omega$	$< 1 \times 10^9 \Omega$	OK
Work surface Rgp main board	$4 \times 10^6 \Omega$	$< 1 \times 10^9 \Omega$	OK
Work surface Rgp main board	$6 \times 10^6 \Omega$	$< 1 \times 10^9 \Omega$	OK
Work surface Rgp main board	$4 \times 10^6 \Omega$	$< 1 \times 10^9 \Omega$	OK
Work surface Rpp main board	$8 \times 10^6 \Omega$	$< 1 \times 10^9 \Omega$	OK
Work surface Rpp main board	$4 \times 10^6 \Omega$	$< 1 \times 10^9 \Omega$	OK

Product:

perfo\_2000\_1000\_ESD  
perfo\_1417\_500\_ESD  
perfo\_1417\_300\_ESD  
perfo\_1117\_1000\_ESD  
perfo\_1117\_500\_ESD  
perfo\_1117\_300\_ESD  
perfo\_935\_500\_ESD  
perfo\_935\_300\_ESD  
perfo\_917\_500\_ESD  
perfo\_917\_300\_ESD  
perfo\_417\_500\_ESD  
perfo\_417\_300\_ESD  
perfo\_417\_100\_ESD

Conclusion:

The product meets the requirements of the standard ČSN EN 61340-5-1 ed.3:2017 Electrostatics - Part 5-1: Protection of electronic components from electrostatic phenomena - General requirements

Appendix 1 - Photo documentation:

